

# 17. TROUBLESHOOTING

ENGINE DOES NOT START OR IS HARD TO START	17-1	SPEEDS	POOR PERFORMANCE AT HIGH SPEEDS
ENGINE LACKS POWER	17-2	POOR HANDLING	17-4
POOR PERFORMANCE AT LOW AND IDLE SPEEDS	17-3		

## ENGINE DOES NOT START OR IS HARD TO START

### Probable Cause

- NOT GETTING TO CARBURRETOR
  - No fuel in tank
  - Clogged fuel line or fuel strainer
  - Clogged float valve
  - Clogged fuel tank breather tube
- WEAK OR NO SPARK
  - Faulty spark plug
  - Fouled spark plug
  - Faulty CDI unit
  - Broken or shorted spark plug wire
  - Faulty alternator
  - Broken or shorted ignition coil
  - Faulty pulse generator
  - Poorly connected, broken or shorted wires
  - Faulty reverse switch
  - Faulty ignition switch
  - Faulty engine stop switch
- LOW COMPRESSION
  - Valve clearance too small
  - Valve stuck open
  - Worn cylinder and piston rings
  - Damaged cylinder head gasket
  - Seized valve
  - Improper valve timing
  - Improperly adjusted decompressor system
- ENGINE FIRES BUT SOON STOPS
  - Choke excessively closed
  - Carburetor pilot screw excessively closed
  - Air leaking past intake pipe
  - Improper ignition timing
  - (CDI unit or pulse generator faulty)
  - Carburetor flooded
  - Carburetor choke excessively open
  - Throttle valve excessively open
  - Air cleaner dirty

1. Check if fuel is getting to carburetor.
  - GETTING TO CARBURRETOR
    - 2. Try spark test.
  - GOOD SPARK
    - 3. Test cylinder compression.
  - COMPRESSION NORMAL
    - 4. Start by following normal starting procedure.
  - ENGINE DOES NOT FIRE
    - 5. Remove spark plug.
    - 6. Start with choke applied.

- WET PLUG
  - Carburetor flooded
  - Carburetor choke excessively open
  - Throttle valve excessively open
  - Air cleaner dirty
- CHOKES EXCESSIVELY CLOSED
  - Carburetor pilot screw excessively closed
  - Air leaking past intake pipe
  - Improper ignition timing
  - (CDI unit or pulse generator faulty)

## ELECTRICAL SYSTEM WIRING DIAGRAM

0030Z-HCO-0000

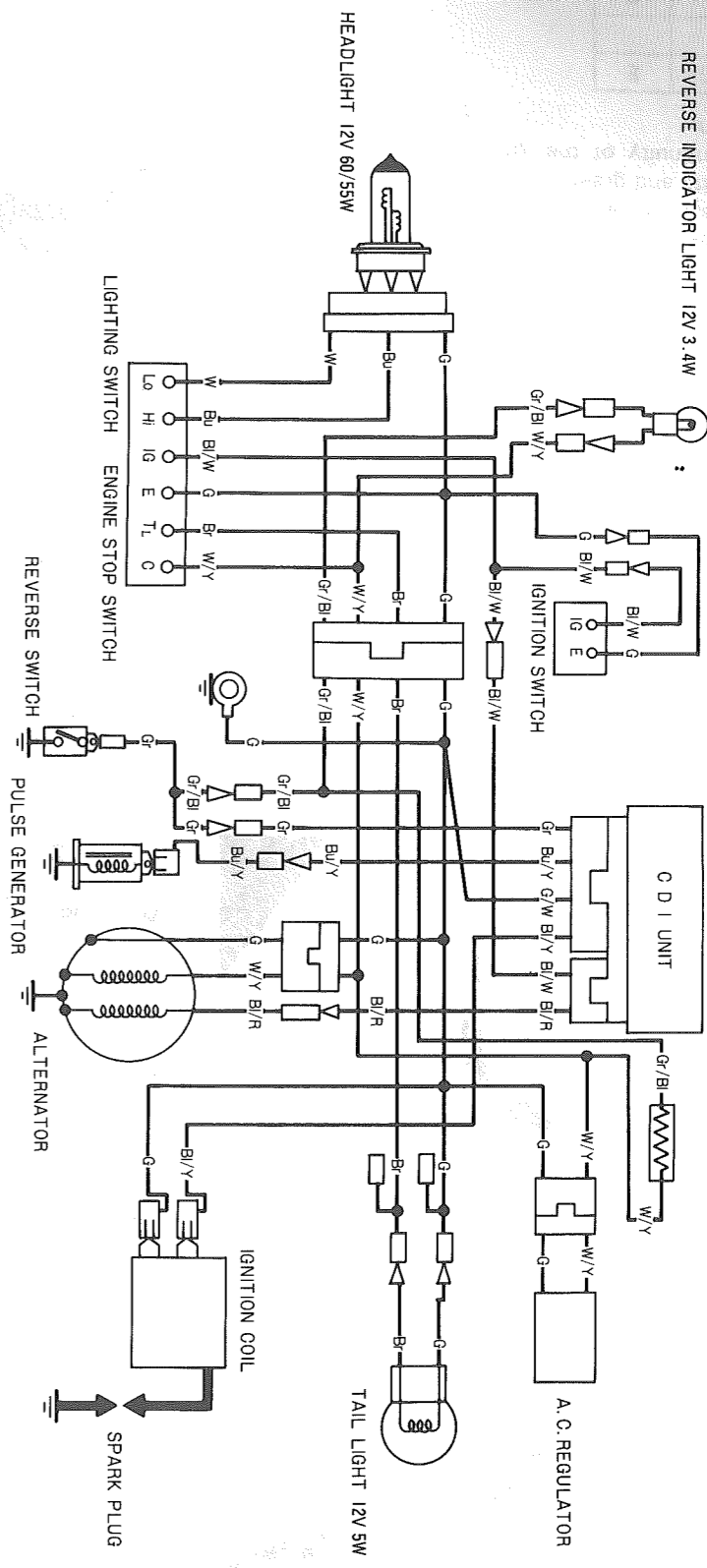

- Bl.....Black
- Y.....Yellow
- Bu.....Blue
- G.....Green
- R.....Red
- W.....White
- Br.....Brown
- O.....Orange
- Lb.....Light Blue
- Lg.....Light Green
- P.....Pink
- Gr.....Grey

IG	E	IG	E
ON	OFF	ON	OFF
BI/W	G	BI/W	G
COLOR			

IG	E	IG	E
OFF	RUN	OFF	RUN
BI/W	G	BI/W	G
COLOR			

Lo	Hi	TL	Lo	Hi	TL
W	Bu	W/Y	W	Bu	W/Y
COLOR					

Lo	Hi	TL	Lo	Hi	TL
W	Bu	W/Y	W	Bu	W/Y
COLOR					